

# Studiomaster<sup>®</sup>

PROFESSIONAL

aspire for more...



## Vāk System

Professional Conference System

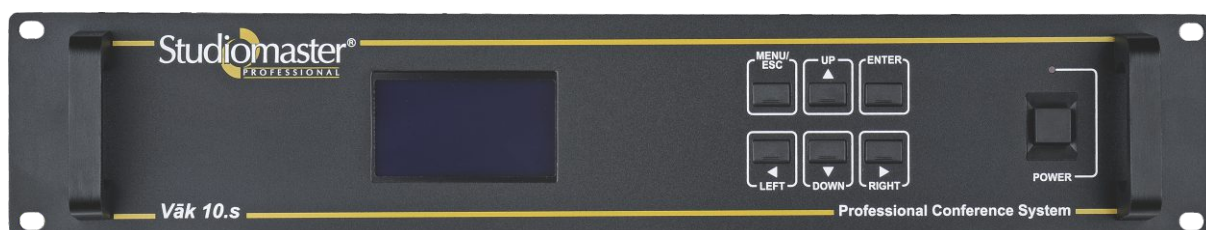



has always been associated as a brand responsible from making cutting edge technology available to a wide spectrum of users, with the right features and with great economic viability. Continuing on this great legacy Studiomaster Professional brings to you the Vāk System – A fully automatic & voice operated conference system.

## Vāk

**In Sanskrit the word “Vākya” is closely related to the word discussions, in the same essence the new conference system from Studiomaster Professional is called the Vāk System.**

The Multi-Functional Studiomaster Professional Vāk Conference System integrates sophisticated state of the art Digital Signal Processing technology with high quality hardware, to bring you the most unique, simple & user-friendly conference system currently available. The system offers a wide range of operational possibilities making it ideal for multiple conferencing applications.

**The Studiomaster Professional Vāk System empowers effortless discussions & facilitates a meeting of minds!**

**The Vāk System Consist of 3 integral components.**

**Vāk 10.s**  
System Controller Unit

**Vāk 10.c**  
Chairman Unit

**Vak 10.d**  
Delegate Unit

## Vāk 10.s Controller Unit

### Features:

- Highly flexible & customizable system supporting 4 Chairman & 160 Delegate Units.
- 4 Channels - Each channel supports 40 delegate units (Total 160 units), & up to 4 chairman units.
- NOM (Number of Open Microphones) - Supports up to 8 active delegate units.
- NOM based gain adjustment.
- Intelligent algorithm & DSP audio processing system.
- Ultra Functional operating modes
- Easy & Quick installation.
- Fully automatic no operator required.
- User friendly interface with LCD display.
- Attractive look & finish.
- Balanced XLR & 1/4” Jack Master output.
- AUX & Line output for recording or monitoring.
- Output signal level controls.
- 19”, 2U Rack Unit Design.

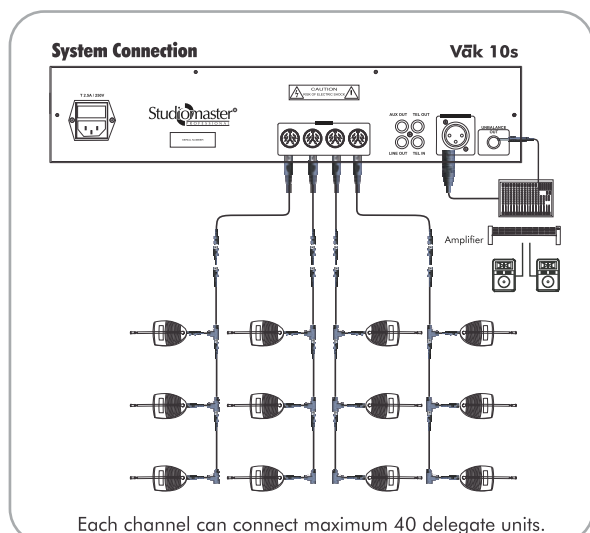

## Ultra Functional Operating Modes:



**Manual Mode:** In this mode all controls are manually operable - subject to the NOM set. The maximum NOM in this system is 8. This feature helps to regulate the meetings.



**FIFO & LIFO:** FIFO (First In First Out) & LIFO (Last In First Out) are ultra flexible & adjustable modes in which the participant enters or exits a discussion.



**Automatic Fixed Time Mode:** In this mode each person gets an allotted time to speak & is muted when the allotted is completed. This mode is ideal for voting based application.



**Fully Voice Operated Mode / Hands Free Mode:** This mode is fully automatic & is activated by voice; hence no hands are required to participate.

## Vāk 10.c / Vāk 10.d Chairman & Delegate Unit



- Detachable & Flexible gooseneck microphone.



- High Quality Panasonic® microphone capsule ensures good voice reproduction.



- LED Indicator on Microphone, to indicate 'Mic Active' status.

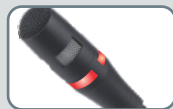

- Built-in speaker with level control.
- 2 Separate Headphone outputs.



- On/Off Talk switch.



- Available in elegant Black & classy White



- Priority Switch to override all delegate units. (Only on Vāk 10.c)
- Unique interrupt mode\*.

\* In any discussion mode when the chairman presses the priority switch he merely interrupts the discussion temporarily. The active delegate units resume their prior status once the chairman releases priority.



## Technical Specification

<b>Vāk 10s</b>	
Power Supply	AV 220V~/50Hz
Current Consumption	1 A
Frequency Response	100-14.5KHz
Signal to Noise Ratio	-81dB
Connector for Delegate / Chairman unit	8P-DINx4
Audio Output	RCA x 2, 1/4" Jack x 1, XLR x 1
Audio Input / Output (TEL)	RCA x 2
REC output level	LINE Output 11dB
Balanced output level	LINE Output 11dB
Audio Input (Telephone)	LINE Input 15dB
Dimension (WxDxH) mm	483 x 323 x 90

<b>Vāk 10c &amp; Vāk 10d</b>	
Connection	Round 8P-DIN x 2.M
Power Supply	DC24V
Max Current Consumption	60mA
Signal to Noise Ratio	-70dB
Sensitivity	-50dB / Pa
Frequency Response	100Hz - 10KHz
Length of Mic Tube	400 mm
Length of Cable	2.1m
Dimension (W x D x H) mm	160 x 170 x 65

### Optional Accessory: Vāk M2 I

- 21" Gooseneck Microphone to be used with Vak 10.d / Vak 10.c base.
- Sold separately. • Color available: Black.



### Ideal Conferencing Solution for...

- Council Halls (Municipal Corporation)
- Parliamentary Chambers
- IT Solution Companies
- State Legislative Assemblies
- Educational Institutions
- Courtrooms



\*Design & specification are subject to change without notice.

StudioMaster® is a registered trademark of Audioplus in India. © Copyright Audioplus, 2008. All rights reserved. Any unauthorized reproduction or use of logos, images or design elements is strictly prohibited by law. No part of the compilation may be reproduced in any manner or translated without written permission.

A1/A2, Giriraj Industrial Estate, Mahakali Caves Road, Andheri (East), Mumbai - 400 093, India Tel.: 022-42869000 / 001  
 Fax: 022-26871453 E: info@audioplus-india.com Website: www.studiomasterprofessional.com & www.audioplus-india.com

Brought to you by  
**AUDIOPLUS**